

Specification Submittal Data / Panasonic Ventilation Fan

Description

Ventilating fan shall be Low Noise ceiling mount type rated for continuous operation. Fan shall be ENERGY STAR rated and certified by the Home Ventilating Institute (HVI). Evaluated by the Underwriters Laboratories and conform to both UL and cUL standards.

Motor/Blower:

- Four-pole totally enclosed condenser motor rated for continuous use.
- Power Rating shall be 120 volts and 60 Hz.
- Fan shall be UL and cUL listed for tub/shower enclosure when used with a GFCI branch circuit wiring.
- Motor equipped with thermal-cutoff fuse.
- Removable with permanently lubricated plug-in motor.

Housing:

- Rust proof paint, galvanized steel body.
- Detachable dual 4" or 6" diameter duct adaptor.
- Built in backdraft damper.
- Expandable extension bracket up to 24".
- Double hanger bar system allowing for ideal positioning.

Grille:

- Attractive design using PP material.
- Attaches directly to housing with torsion springs.

Warranty:

- ALL Parts: For period of 3 years from the date of the original purchase.

Architectural Specifications:

Ventilating fan shall be of the ceiling mount, ENERGY STAR rated type, with no less than 110 CFM and no more than less than <0.3 sone as certified by the Home Ventilating Institute (HVI) at 0.1 static pressure in inches water gauge (w.g.) and with no less than 91 CFM and no more than 0.5 sone as certified by HVI at 0.25 w.g. Power Consumption shall be no greater than 21.1 watts at 0.1 w.g. and 20.7 watts at 0.25 w.g. ENERGY STAR rated with efficiency of no less than 5.3 CFM/watt at 0.1 w.g. and 4.5 CFM/watt at 0.25 w.g. The motor shall be totally enclosed, four pole condenser type engineered to operate continuously. Power rating shall be 120v/60Hz. Included is a detachable dual 4" or 6" diameter duct adaptor. Duct diameter shall be no less than 4". Fan shall be UL and cUL listed for tub/shower enclosure when used with GFCI branch circuit wiring. Fan shall be ASHRAE 62.2, LEED, ENERGY STAR IAP, EarthCraft, California Title-24, and WA Ventilation Code compliant.

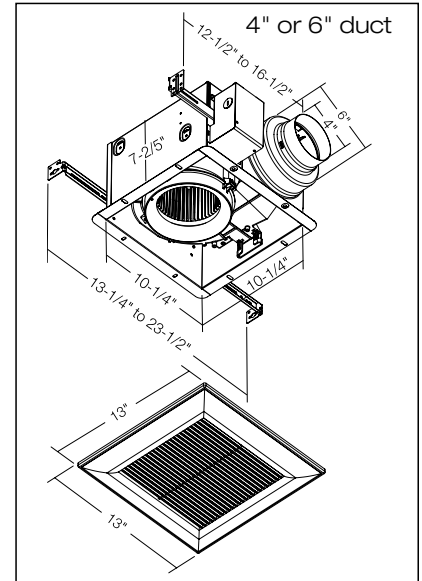

FV-11VQ5

Specifications: WhisperCeiling FV-11VQ5		4" or 6" Duct (Standard)	
Ventilation Fan Characteristics (HVI tested data for 0.1" S.P.)	Static Pressure in inches w.g.	0.1	0.25
	Air Volume (CFM)	110	91
	Noise (sones)	<0.3	0.5
	Power Consumption (watts)	21.1	20.7
	Energy Efficiency (CFM/Watt)	5.3	4.5
	Speed (RPM)	950	1161
	Current (amps)	0.18	0.17
	Power Rating (V/Hz)	120/60	
	ENERGY STAR rated	YES	

As of date 4/11

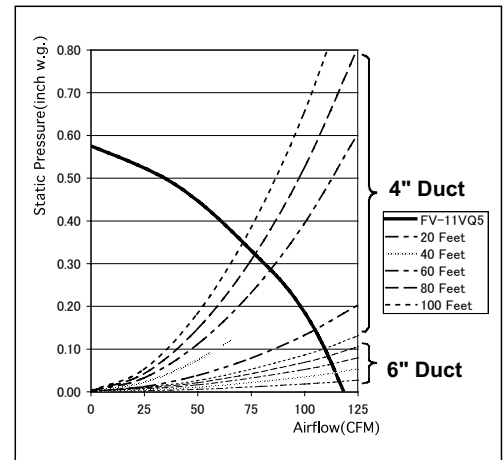

For complete Installation Instructions visit www.panasonic.com/building

Model	Quantity	Comments	Project:
			Location:
			Architect:
			Engineer:
			Contractor:
			Submitted by:
			Date:

Panasonic Home and Environment Company
Division of Panasonic Corporation of North America
One Panasonic Way
Secaucus, NJ 07094

www.panasonic.com/building

